

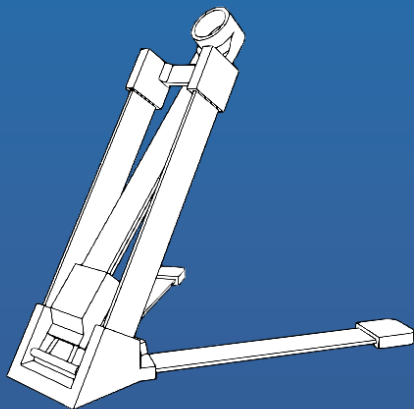

MARSHMALLOW MAYHEM CATAPULT KIT



TEAM BLUE GUIDEBOOK

Dear Fellow Mad Scientist,

Greetings! I extend my sincerest gratitude for your decision to join Team Blue. As you assemble your catapult, remember that Team Blue has the coolest, calmest, and most calculating mad scientists in the world.

Have fun and stay safe in your dedication to spreading chaos and marshmallow-filled mayhem. Remember, world domination starts in your own home!

Diabolically yours,
Dr. JJ Mauvais

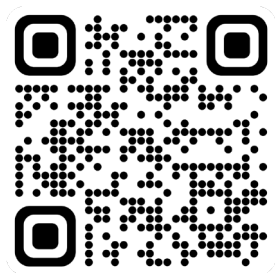

Build along with me!
mischief-tech.com/catapult

ASSEMBLY TIPS

- 1 Fittings are designed to be tight to help prevent the catapult pieces from disconnecting when launching sugary sabotage.
- 2 If you are having trouble putting pieces together try placing one on carpet or a rug to help hold it in place while you press on the other.
- 3 You can also sand, scrape, or shave down the wooden pieces to fit more loosely.
- 4 Feel free to take apart, combine, and remix kits to make your own mad creation!



SAFETY

Warning: Do not aim at eyes or faces. Wear goggles or glasses to shield your eyes. Use only soft projectiles, such as mini marshmallows. Keep all projectiles away from small children and pets to avoid choking risks. Adult supervision is recommended.

ASSEMBLY

1

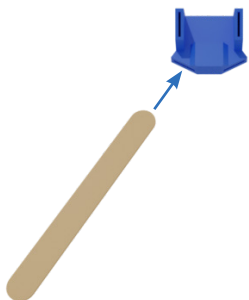

2

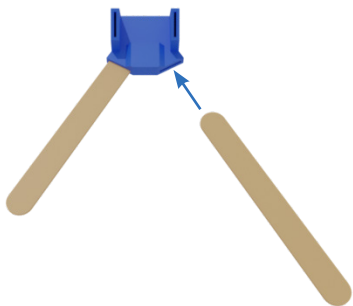

3

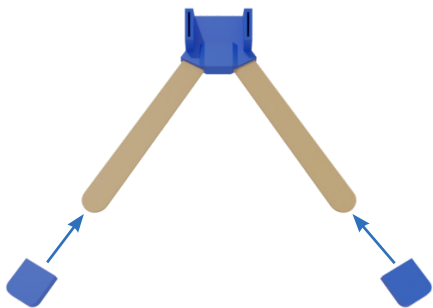

4

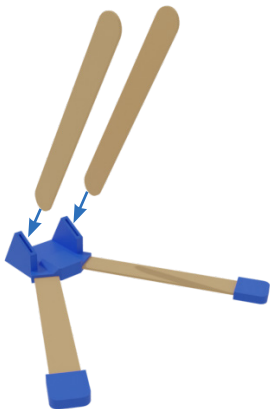

ASSEMBLY

5

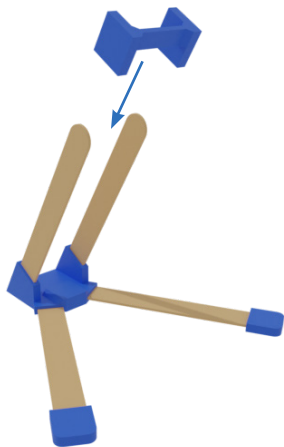

6



* Use two sticks

7

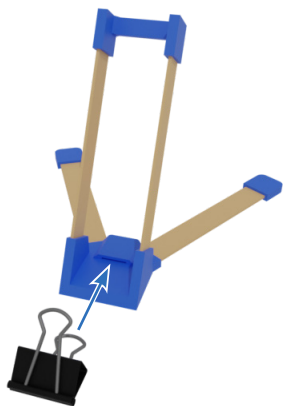

8

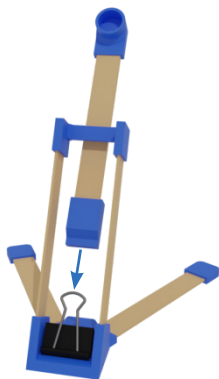

READY FOR BATTLE

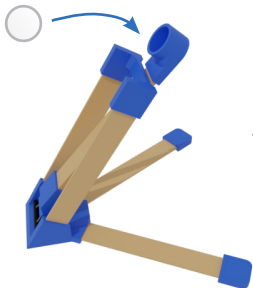

Load marshmallow in the bucket

Pull arm back

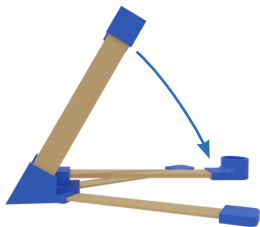
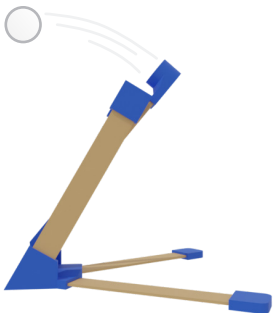

Release and let it fly!

GAME IDEAS

1

Red vs. Blue

Form two teams. Each hit to the opposing team scores your team a point. First to 50 points wins. *Remember: avoid aiming for eyes and faces. Eye protection is recommended.*

2

Target Practice

Use cups, bowls, or cardboard boxes as targets. See how many marshmallows you can make into the targets.

3

Marshmallow Marathon

Time yourself to see how quickly can you launch 50 marshmallows. Go head-to-head with a friend and find out who is the best.

4

Accuracy Test

Launch marshmallows straight up in the air and try to catch them with your mouth. Try shooting them for someone else to catch. A higher arc makes it easier to catch.

SCORE CARDS

TEAM NAME

Round Score Win/Lose

1		
2		
3		
4		
5		
6		
7		
8		
9		
10		
11		
12		
13		
14		
15		
16		
17		
18		

TEAM NAME

Round Score Win/Lose

1		
2		
3		
4		
5		
6		
7		
8		
9		
10		
11		
12		
13		
14		
15		
16		
17		
18		

TEAM NAME

TEAM NAME

Round Score Win/Lose

1		
2		
3		
4		
5		
6		
7		
8		
9		
10		
11		
12		
13		
14		
15		
16		
17		
18		

Round Score Win/Lose

1		
2		
3		
4		
5		
6		
7		
8		
9		
10		
11		
12		
13		
14		
15		
16		
17		
18		



mischief-tech.com

© 2024 Sparkwell Creative LLC d.b.a. Mischief Tech
All Rights Reserved